

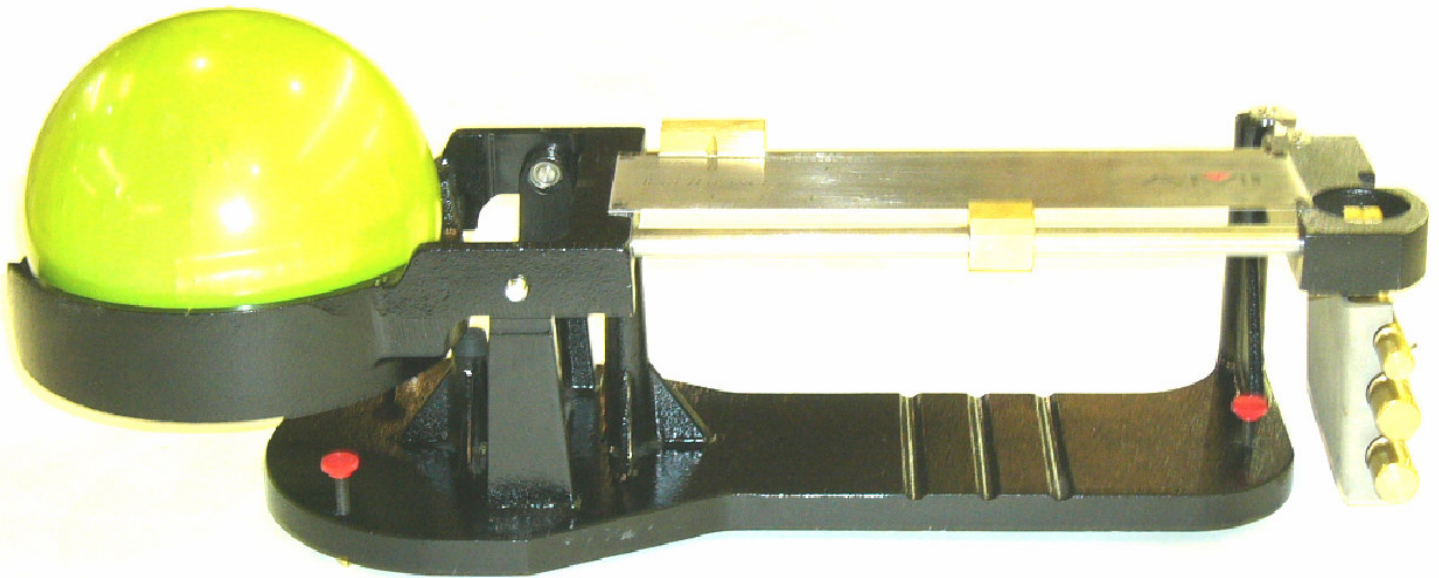

QUBICAAMF



Accu-Balance

Bowling Ball Scale

022 444 401

**General instructions for balancing
bowling balls to USBC gross weight
and do-do weight specifications.**

Document # 022 444 401P

Issue Date: Jan. 06

Technical Support (International) 804 730-4000 (Domestic) 1-866-460-7263

Copyright 2005, QubicaAMF Bowling, 8100 AMF Drive, Mechanicsville, VA 23111

Features and Benefits

- Weighs bowling balls from 5 to 17 pounds.
- Six precision ball bearings within the weighing ring for easy ball movement in all directions. No need to pick up bowling ball during the weighing process.
- Has very clear-cut graduations that are easy to read.
- Has a back weight beam graduated in quarter ounces to a total of two pounds.
- Furnished with (2) four-pound and (1) two-pound barrel counterpoise weights, accurately calibrated.
- Counterpoise weights are locked on so they do not fall off in normal use, yet are very easy to remove and store.
- The complete counterpoise weight assembly can be quickly removed for checking “zero” balance.
- Has a trimming weight for perfect “zero” balance, conforms to weights and measures and USBC standards, and has a built-in level to ensure accurate leveling of the scale. Three leveling screws position the scale easily in all directions.
- Comes complete with precision ball bearing pivot bearing which can be easily replaced.
- To preserve the finish, barrel weights and poises are polished brass, small parts are chrome plated and the frame is finished with a rich cracked black lacquer enamel.

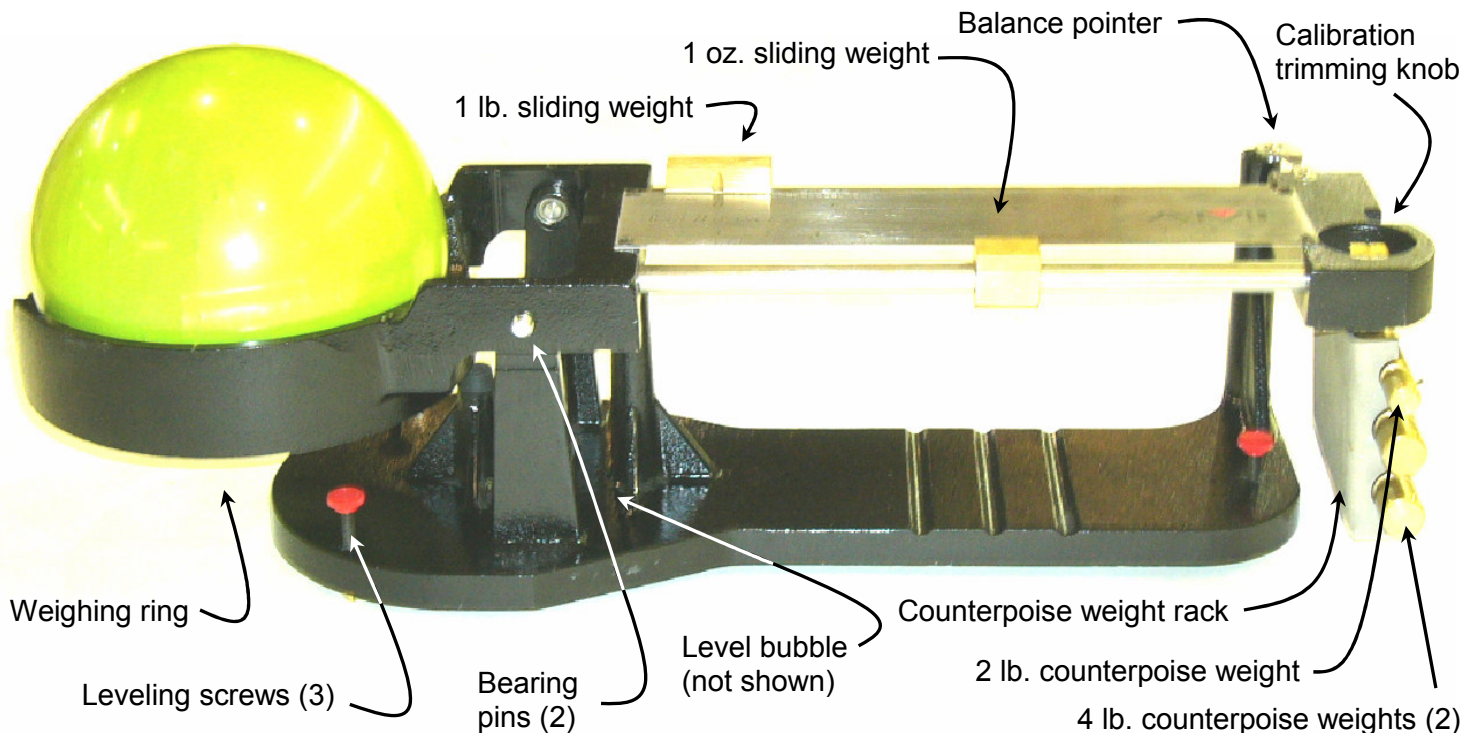

For rules and specification information:

United States Bowling Congress
 Bowling Headquarters
 5301 South 76th Street
 Greendale, WI 53129
 1-800-514-BOWL (2695)
 Email: bowlinfo@bowl.com
 Website: www.bowl.com

For product support information:

QubicaAMF Bowling Worldwide
 Consumer and Support Products
 8100 AMF Drive
 Mechanicsville, VA 23111
 1-866-460-QAMF (7263)
 Email: info@qubicaamf.com
 Website: www.qubicaamf.com



General Drilling Specifications

The United States Bowling Congress Drilling Specifications state that the following tolerances shall be permissible in the balance of a bowling ball used in sanctioned competition:

1. For a ball weighing 10.01 pounds or more:
 - A. Not more than three ounces difference between top half of the ball (finger hole side) and the bottom half (side opposite finger holes).
 - B. Not more than one ounce difference between the sides to the right and left of the finger holes or between the sides in front and back of the finger holes.
 - C. A ball drilled without a thumb hole may not have more than one ounce difference between any two halves of the ball.
 - D. A ball drilled without any finger holes or indentations may not have more than one ounce difference between any two halves of the ball.
 - E. A ball used without any hole or indentations may not have more than one ounce difference between any two halves of the ball.
2. For a ball weighing 10.0 pounds to 8.0 pounds:
 - A. Not more than two ounces difference between top half of the ball (finger hole side) and the bottom half (side opposite the finger holes).
 - B. Not more than $\frac{3}{4}$ ounce difference between the sides to the right and left of the finger holes or between the sides in front and back of the finger holes.
 - C. A ball drilled without a thumb hole may not have more than $\frac{3}{4}$ ounce difference between any two halves of the ball.
 - D. A ball drilled without any finger holes or indentations may not have more than $\frac{3}{4}$ ounce difference between any two halves of the ball.
 - E. A ball used without any hole or indentations may not have more than $\frac{3}{4}$ ounce difference between any two halves of the ball.
3. For a ball weighing less than 8.0 pounds:
 - A. Not more than $\frac{3}{4}$ ounce difference between the top half of the ball (finger hole side) and the bottom half (side opposite the finger holes).
 - B. Not more than $\frac{3}{4}$ ounce difference between the sides to the right and left of the finger holes or between the sides in front and back of the finger holes.
 - C. A ball drilled without a thumb hole may not have more than $\frac{3}{4}$ ounce difference between any two halves of the ball.

- D. A ball drilled without any finger holes or indentations may not have more than $\frac{3}{4}$ ounce difference between any two halves of the ball.
- E. A ball used without any hole or indentations may not have more than $\frac{3}{4}$ ounce difference between any two halves of the ball.

Permissible Ball Imbalances

	Top-Bottom	Left-Right	Front-Back
>10#	3 oz	1 oz	1 oz
≤10# - ≥8#	2 oz	$\frac{3}{4}$ oz	$\frac{3}{4}$ oz
<8#	$\frac{3}{4}$ oz	$\frac{3}{4}$ oz	$\frac{3}{4}$ oz

The Six Sides of a Bowling Ball

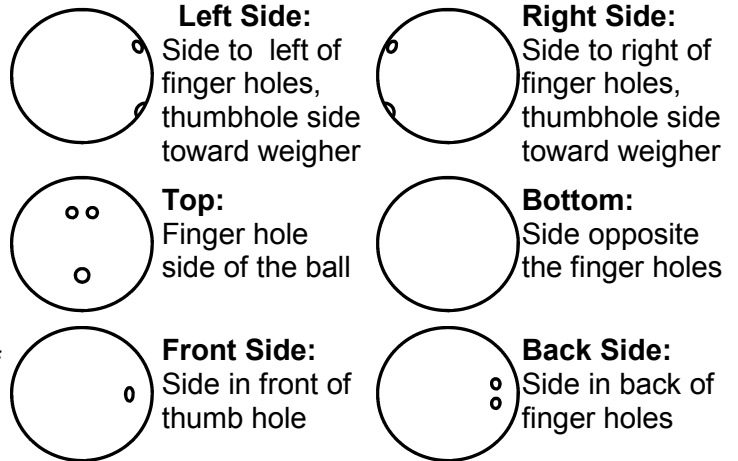

IMPORTANT: Before any accurate weighing can be performed on this scale, it must be in perfect levelness. This is accomplished by turning the leveling screws until bubble level is centered and balance pointers are in direct alignment.

While this scale was manufactured primarily to detect do-do balls (balls out of balance), it has been proven that by placing the ball on any approved and recently tested gross weight beam scale, the gross weight may be accurately determined on this AMF Accu-Balance Scale.

NOTE: Recalibration of this scale requires special weights and precise procedures. Contact QubicaAMF Technical Support at 866-460-7263 for assistance in returning scale to the manufacturer for recalibration.



Determining Ball Imbalances

Position No. 1 — Determining the gross weight and Starting point for weighing left side

When the weigher has become familiar with the provisions of Rules and the six indicated bowling ball sides s/he is then ready to proceed providing the scale is in perfect levelness. Before determining the difference between any two sides of a bowling ball, a so-called gross weight or starting point must be considered in arriving at the proper balance. This is done by placing the ball in the scale (centered) as shown in Position 1 with the thumb hole toward weigher.

Be certain the balance beam is set at zero while the poise on the weight beam is being adjusted to determine gross weight.

This is the starting point in arriving at the difference between the right and left sides of the ball, the poise on the balance beam in every instance remaining at zero in making this first test.

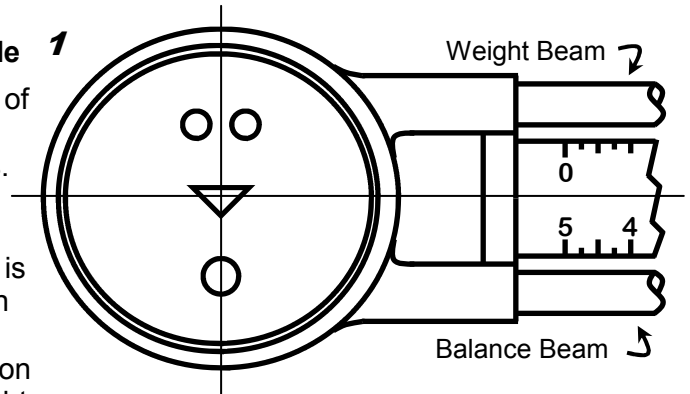

Position No. 2 — Weighing the right side of ball and proving gross weight

This position is obtained by rotating the ball one half turn and centered with the thumb hole furthest from weigher. If the beam is not in balance after turning the ball to position 2, the poise on the balance beam (in front) should be moved accordingly from zero until the beam is again in balance. Then a reading shall be taken to determine the difference in balance between the right and left sides of the ball. This is the side weight.

Determining Gross Weight: Average the weights found in Positions 1 and 2. Example: If Position 1 indicates 15 lbs., 15 ¾ oz. and Position 2 indicates 16 lbs., ¼ oz., the Gross Weight is 16 lbs., 0 oz.

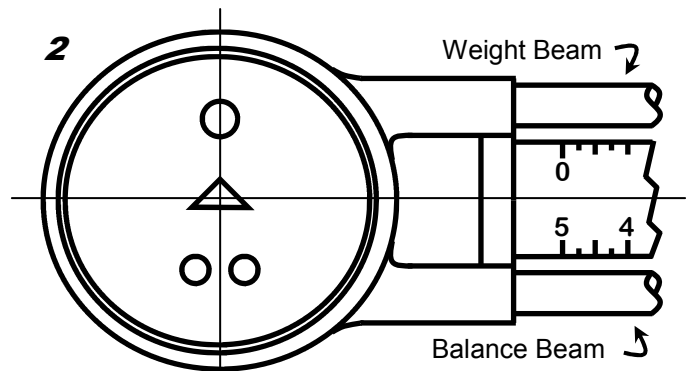

Position No. 3 — Weighing top of ball

With the ball still in the scale as shown in Position No. 2, give the ball one quarter turn to left so that finger hole center line is parallel and aligned to the edge of the ball ring. This will place the ball into Position No. 3. Zero the poise on the balance beam and use only the poise on the weight beam to balance. In most cases it will be necessary to move poise on the weight beam to the right, which indicates the ball is plus (or heavy) on the top side of the ball.

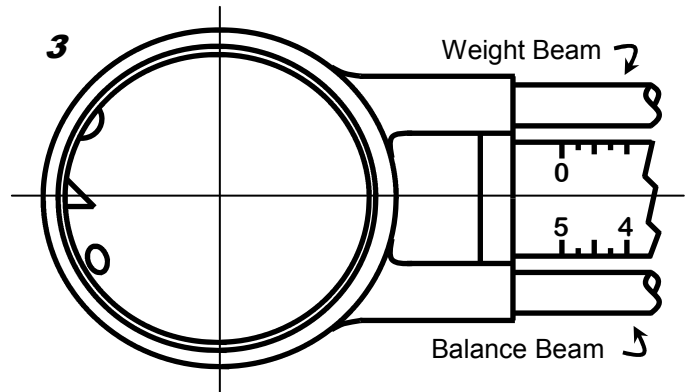

Position No. 4 — Weighing bottom of ball

Give the ball one-half turn to the right so that finger holes center line is parallel and aligned to the edge of the ball ring. This will place ball into Position No. 4. The poise on the weight beam remains undisturbed. Then proceed to balance the scale by moving the poise on the balance beam. In most cases the poise will be moved to the left causing the ball to be minus (or light) on the bottom side. Read the imbalance directly from the balance scale. The ± will be in the same direction as the poise moved relative to the pivot.

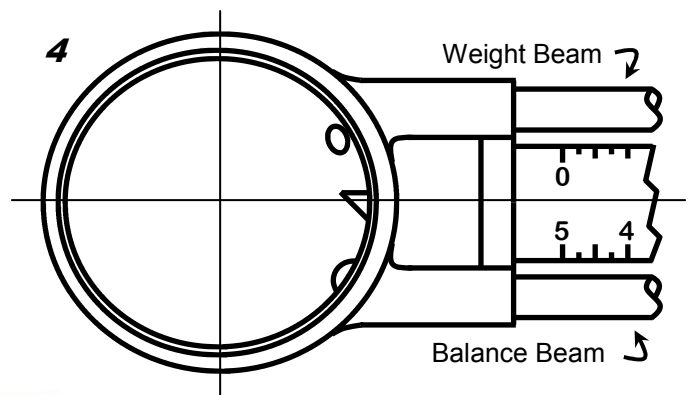

Position No. 5 — Weighing front side of ball

The position of the ball should now be changed in order to weigh the front side of ball. This is done by placing the ball in scale as shown in Position No. 5, with the finger holes centered in a straight line through the length of ball scale with the thumb hole placed to the left. Zero the poise on the balance beam, then move poise on the weight beam until it is balanced.

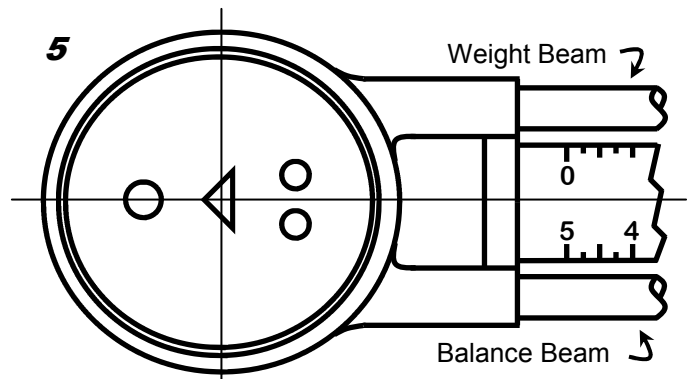

Position No. 6—Weighing back side of ball

The position of the ball is reversed by giving it a half turn. Weigh the back side of the ball as shown in Position No. 6 with the finger holes again centered in a straight line and the thumb hole placed to the right. Adjust poise on the balance beam, taking a reading from the balance scale to determine the front-back imbalance of the ball.



Determining Center of Gravity

1. Starting with an undrilled ball, draw a line through the label, centering that line with a Quarter Scale (part number 022 444 002) (fig. 1)
2. Balance scale, using balance poise to trim.
3. Rotate ball one quarter turn. (fig. 2)
4. Shift ball left or right until scale balances.
5. Center quarter scale on ball and draw a perpendicular line intersecting the previous line. (fig. 3)
6. Rotate ball one quarter turn. (fig. 4)
7. Repeat step 4.
8. Repeat step 5. (fig. 5)
9. Rotate ball one quarter turn. (fig. 6)
10. Repeat step 4.
11. Repeat step 5. (fig. 7)
12. Connect corners of box. (fig. 8)
13. "X" marks the Center of Gravity.

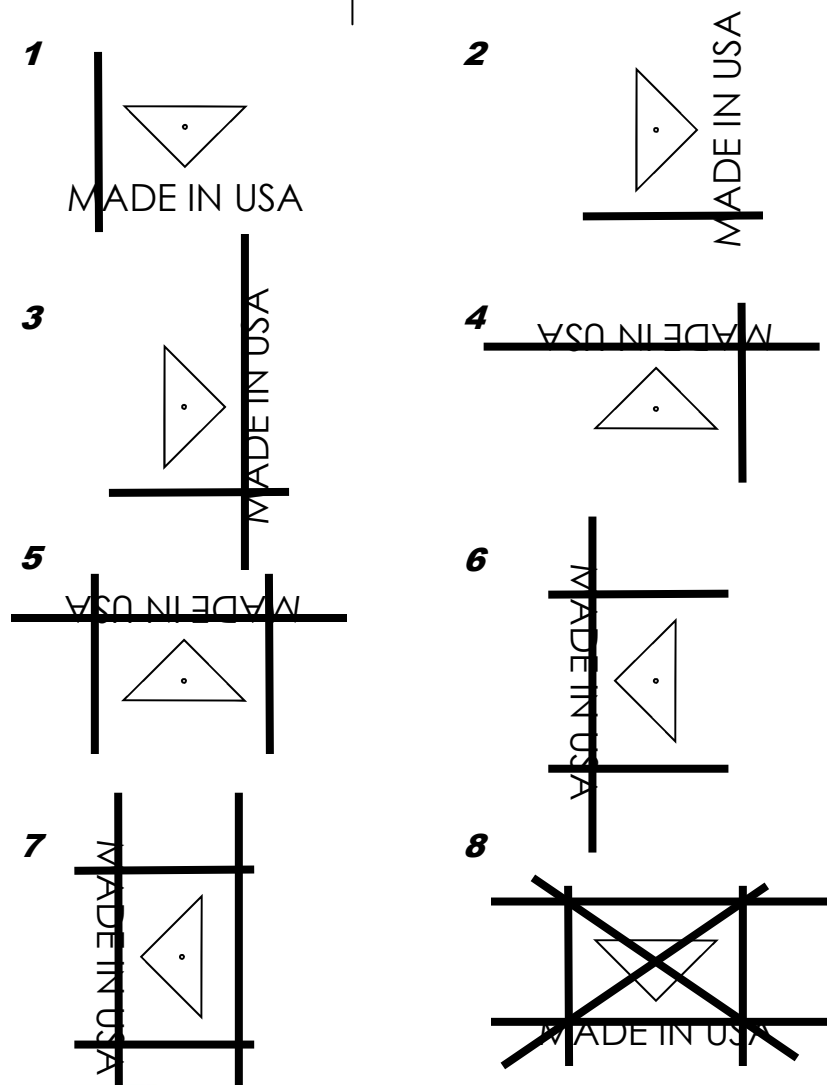

WARRANTY:

For any questions or concerns about the operation of your Accu-Balance Bowling Ball Scale, please contact QubicaAMF's Consumer & Support Products Division at 1-866-460-7263.

WARRANTY PERIOD: ONE (1) YEAR.

This warranty is subject to the following conditions and limitations:

1. QubicaAMF shall not be liable for loss of profits or other direct or indirect costs, expenses, losses or damages arising out of defects in the Equipment.
2. This warranty is extended to, and may be enforced only by the original Purchaser or the assignee named on the face of the invoice.
3. Purchaser shall maintain house temperature and humidity conditions as outlined in the Pinspotter Maintenance Manual during the Installation period and at all times thereafter.
4. Replacement parts or materials shall be delivered to Purchaser at the place of Installation or original delivery.
5. Notice of any defects must be sent to QubicaAMF by Purchaser and received by QubicaAMF no later than ten (10) days after expiration of each Warranty for such Warranty to apply.
6. The defect must not have been caused by carelessness, improper treatment (whether by inexperienced users or otherwise) or any willful or negligent act or omission (including any failure to comply with instructions given by QubicaAMF).
7. In no event will QubicaAMF be liable for any damages caused by the Customer's failure to perform the Customer's responsibilities in caring for QubicaAMF products.
8. QubicaAMF shall not assume any other liability in connection with the QubicaAMF Equipment.
9. THIS WARRANTY IS MADE IN LIEU OF ANY OTHER EXPRESSED OR IMPLIED WARRANTIES, INCLUDING ANY IMPLIED WARRANTY OF MERCHANTABILITY OR FITNESS FOR A PARTICULAR PURPOSE, AND IN LIEU OF ANY OTHER OBLIGATION ON THE PART OF QUBICAAMF.
10. QubicaAMF shall have no liability whatsoever if repairs or replacements are made by anyone not approved in advance by QubicaAMF in writing.
11. QubicaAMF warranty is limited as stated herein.

